

Installation Instructions



DAVEY

RAINBANK[®]

household water savings



- Installation
- operation
- trouble shooting

For any assistance or after sales service contact your Davey Dealer. For help in locating your closest dealer contact your appropriate **Davey Customer Service Centre** listed on the back of this booklet.



Available from www.EcoPoint.net.au

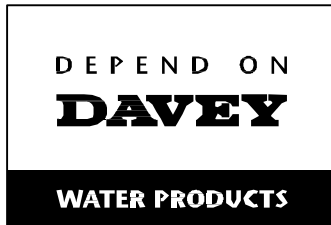

Davey Water products manufactures and distributes a comprehensive range of water transfer, conservation and filtration products which have been proven throughout the world over the past seventy years.

our export markets now number more than 60 separate countries where Davey Water products match or exceed the world's best and achieve results in some of the toughest environmental and climatic conditions on the globe.

over the past few years Davey Water products has added several businesses to the group which add important new opportunities as well as rounding out our product range. these are :-

- spa-Quip, the new Zealand based manufacturer of spa pool products, which compliments the range of Davey swimming pool and spa bath products.
- contamination control, another new Zealand based company, whose range of water treatment products for domestic, rural, industrial and commercial water supply applications holds a dominant position in that market.
- Monarch pool systems, an australian based company, with an extensive range of swimming pool products and a market leader in salt water chlorination technology. they have an extensive manufacturing capability in australia.

all of these companies export water products to the world market, continuing in the Davey tradition.

Davey have also maintained our significant commitment to research and development which has created innovative new products servicing specific and emerging market opportunities.

Many of these products have received multiple awards for innovation and product excellence and led to our induction into the Manufacturing hall of Fame for the state of Victoria.

Davey Water products is a wholly owned subsidiary of guD, a 'top 00' australian public company whose shares are listed on the australian stock exchange.

now more than ever "Depend on Davey Water products" reflects a business culture of leadership, innovation, quality products and an accredited agent and reseller network committed to meeting the best expectations of our customers.

contents

about rainbank® . the easy way to save water.	4
two types of installation - quick reference	5
how rainbank® works	6
how to install rainbank®	7
before you start	9
Installation instruction	11
pump outside tank option - overall	1
pump outside tank option - close up	1
pump inside tank option - overall	14
pump inside tank option - close up	15
Installation of submersible pumps	5
priming pumps	6
Maintaining rainbank®	8
trouble shooting rainbank®	9
Warnings	
Davey guarantee	5
contact Details	6

about rainbank®. the easY WaY to saVe Water

congratulations on your purchase of a high quality australian made Davey rainbank® automatic water controller. rainbank® is patented and has been fitted to thousands of australian homes.

- rainbank® allows you to use water from your rainwater tank for your toilet, washing machine or garden whenever there is water in the tank.
- If the tank water is exhausted rainbank® automatically and seamlessly switches you over to mains water.
- rainbank® has an in-built “dual check valve” for low hazard back flow prevention.

RainBank® can save up to 40% of your home's usage of mains water, which could be up to 100,000 litres of water a year.

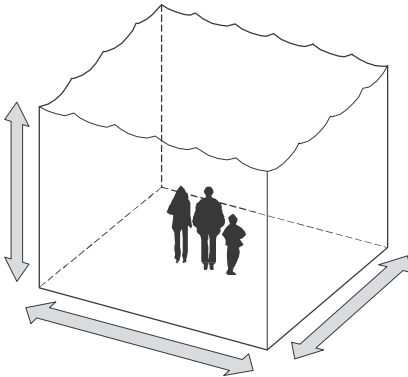

100,000 Litres

Your actual savings depend on your roof catchment area, rainfall and the size of your tank.

RainBank® may allow you to claim tank rebates (when installed on existing homes).

In most areas of australia, having a rainbank® and using rainwater for your toilet and washing machine allows you to claim tank rebates paid by state governments and some councils.

RainBank® is energy efficient and cheap to run.

because rainbank® only works when it is needed it uses very little energy.

the daily power used to run a rainbank® and pump system supplying two toilets in a three person dwelling is equivalent to:

- a reverse cycle air conditioner for minutes
- a clothes dryer for minutes
- a washing machine for 10 minutes
- a tV or pc for 0 minutes

two types of Installation

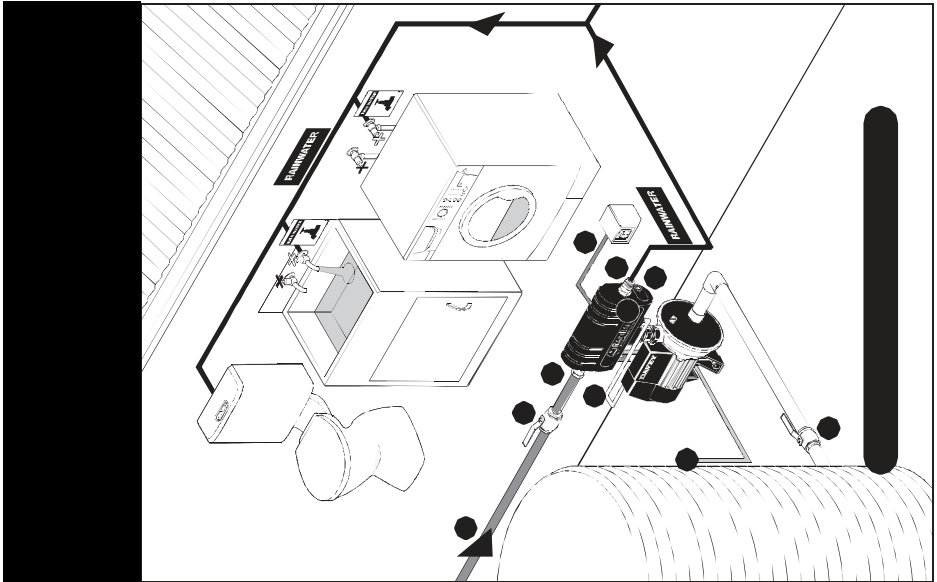
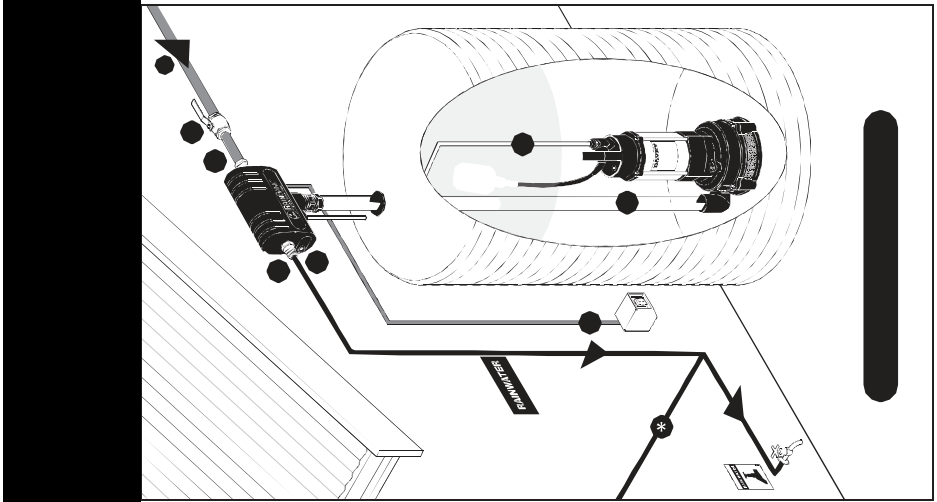
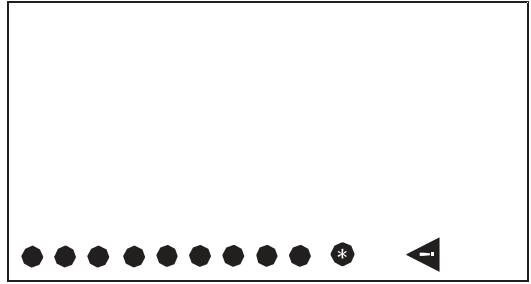

hoW rainbank® Works

1. When there is demand for water from your toilet, washing machine or garden tap rainbank® senses this demand and checks the level of water in the rainwater tank.
note: demand must be greater than 1.5 litres per minute or mains water will be delivered.
2. If there is rainwater in the tank rainbank® switches on the pump. the pressure of the pump is sufficient to overcome the pressure of the mains water inside rainbank® and this closes a dual check valve and allows the rainwater to flow.
note: mains water pressure is limited to 100kpa.
3. When there is no longer a demand for water, rainbank® detects that water has ceased to move inside the pipes, switches off the pump and waits for another water demand.
4. If rainbank® senses a water demand and detects insufficient water in the rainwater tank it will automatically allow the mains water to flow.
5. If there is a power failure during a demand for water rainbank® will automatically supply the mains water as backup.

What are the advantages of RainBank® over conventional air-gap systems?

- rainbank® is totally hands off for your customer and needs no maintenance or adjustment.
- rainbank® is easy to install.
- rainbank® does not require mains water to be re-pressurised and therefore saves energy.
- rainbank® is WaterMark approved - this means plumbing inspections will be approved & your insurance should cover installation faults.
- rainbank® will provide mains water as backup when:
 - there is no rainwater
 - there is no electricity to run pump
 - the pump has been removed for servicing – air-gap system rely on pumps to pressurise the water and do not function without them.

⚠ IMPORTANT

because it involves mains water, rainbank® may only be legally installed by a licensed plumber. hardwired rainbanks may also require an electrically qualified person to install and remove.

Different types of RainBank® Installations

there are different ways a rainbank® can be installed depending on your rainwater tank and pump configuration.

INStAIIATION TyPe 1 - Page 16

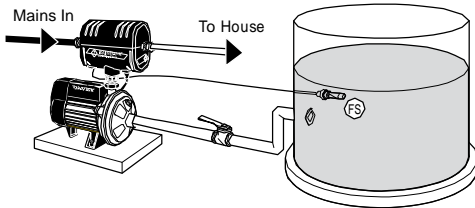

Tank: above ground
Pump: outside tank
Float switch: must be installed inside of tank
Pump Kit: krb50 or krb60

INStAIIATION TyPe 2 - Page 21

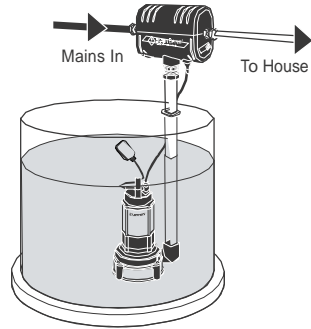

Tank: above ground
Pump: submersible inside tank
Float switch: incorporated with pump
Pump Kit: krb4

INStAIIATION TyPe 3 - Page 22

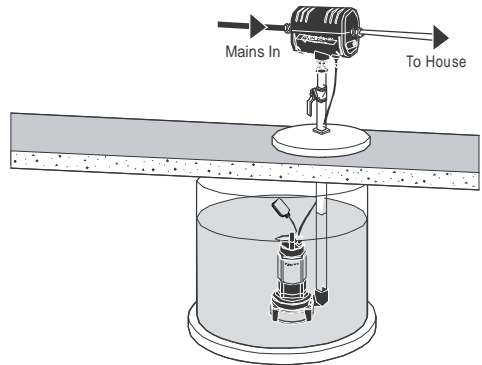

Tank: below ground
Pump: submersible inside tank
Float switch: incorporated with pump
Pump Kit: krb4

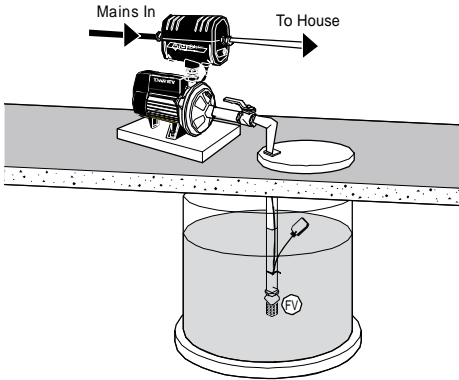

Tank: below ground

Pump: suction above ground needs foot valve

Float switch: this is a different type of float switch suitable for tanks that you don't want to drill holes into. (part number 1 449) see your Davey Dealer for details

Pump Kit: krb50 or krb60

Float: part number 1 449

OTHeR INsTAlIATION TyPes

note: there are some situations where an alternate method to sense the rainwater level is required.

- tanks with a rubber or plastic membrane (check with tank manufacturer).
- concrete tanks

there is an alternative float switch that can be lowered into the top of these types of tanks. this is part number 1 449.

Different ways of installing the RainBank® unit itself.

- exposed installation against wall (under eaves).

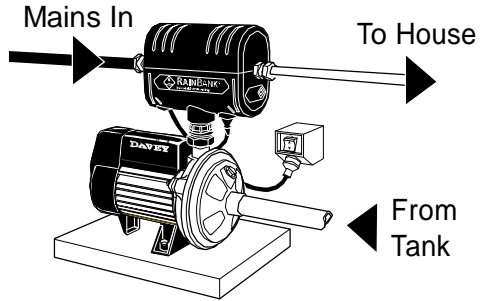

- encased installation with unit and pump inside cover.

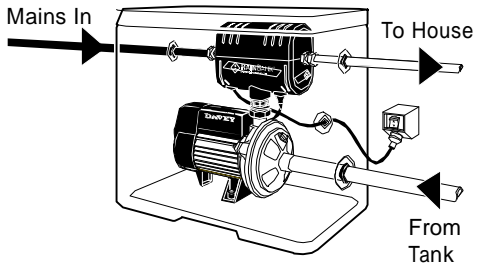

- Integrated installation incorporated as part of tank system.

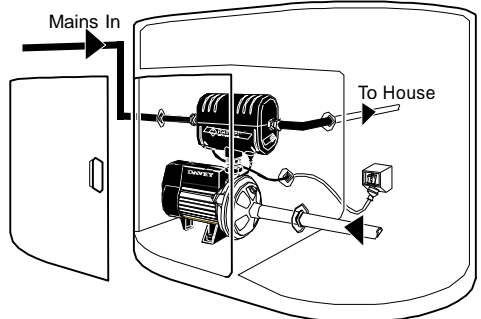

beFore You start

IMPORTANT:

- If you are in doubt about any aspect of your rainbank® kit's suitability, check with your Davey dealer. For help in locating your closet dealer call the appropriate Davey customer service centre listed on the back of this booklet.
 - rainbank® is designed to handle clean rainwater and mains water. It should not be used to interconnect as part of a bore water, dam water, grey water, stormwater or recycled water system.
 - Make sure the wiring, plumbing and the rainbank® unit are protected from access by children and pets.
- Fit a first flush system if possible to divert the initial run of water from the roof that may contain dirt and pollutants.
 - Fit a strainer to the top of your tank inlet to stop leaves entering the system.
 - Fit a 1 inch 'Y' strainer to the pipe work between the pump and rainwater tank – or between the pump and rainbank®. This will ensure that debris from the tank will not build up inside rainbank®, washing machines or toilet cisterns.
 - use at least 0mm or 1/4 inch plumbing to and from rainbank® to reduce the effect of pipe friction.

Other things we recommend to maximise the performance and serviceability of your RainBank®.

Make sure the delivery from rainbank® to your home is within the following pipe length limits:

pipe diameter	Max. pipe length @ 6 lpm flow	Max. pipe length @ 1 lpm flow
15mm	8m	10m
18mm	90m	7m
20mm	5m	15m

For each bend or tee you should reduce the above distances by 0.5m.

- We recommend fitting isolation valves to the rainwater and mains water pipe so that the rainbank® can be easily and conveniently removed if required. This saves both wasting rainwater and having to turn off the mains supply if the unit ever has to be removed.
- While rainbank® does have an in-built Dual check back flow prevention valve, some water authorities require an additional external back flow valve to be plumbed into the mains water delivery line, to prevent any possible contamination of mains water by rainwater, particularly if the tank is partially or fully submerged. Check with your local water authority for their plumbing guidelines on rainwater tanks.

Installation Instructions

Things you should be aware of:

- before installing rainbank® please read all instructions carefully as failures caused by incorrect installation are not covered under warranty.
- rainbank® is designed to handle clean water and should not be used for any other purpose without specific referral to Davey. the use of rainbank® to pump flammable, corrosive or other materials of a hazardous nature will damage the system and void the warranty.
- the pumping of abrasive materials will damage the system and void the warranty.
- Water freezing inside the rainbank® will damage the unit. locate your rainbank® and pump so that they are not susceptible to freezing.
- some insects such as small ants find electrical devices attractive for various reasons. If your controller or pump is susceptible to insect infestation you should implement a suitable pest control plan.
- an inline 'Y' strainer between the pump (or before the pump) and the rainbank® controller is recommended to stop foreign matter entering the unit and damaging it.
- all pipe work and fittings should be labelled in accordance with local standards such as Australian standard AS/NZS 500. this standard requires that all pipework containing rainwater is marked with green 'rainwater' tape or stickers at 1 meter intervals and every outlet that may deliver rainwater is to be permanently signed with 'rain Water' signage or a green tap marked 'rW'.
- ensure all wiring, plumbing and the rainbank® unit are protected from access by pets and/or children.
- Mains electrical connections and checks must be made by a qualified electrician and comply with applicable local standards. the 1 volt connections need not be carried out by a qualified electrician, but should be done in compliance with applicable standards.
- In accordance with AS/NZS 50 we are obliged to inform you that this controller and any pump controlled by it is not to be used by children or infirm persons and must not be used as a toy by children.

puMp outSIDe tank
optlon - oVerall

MoDel no. krb50/60

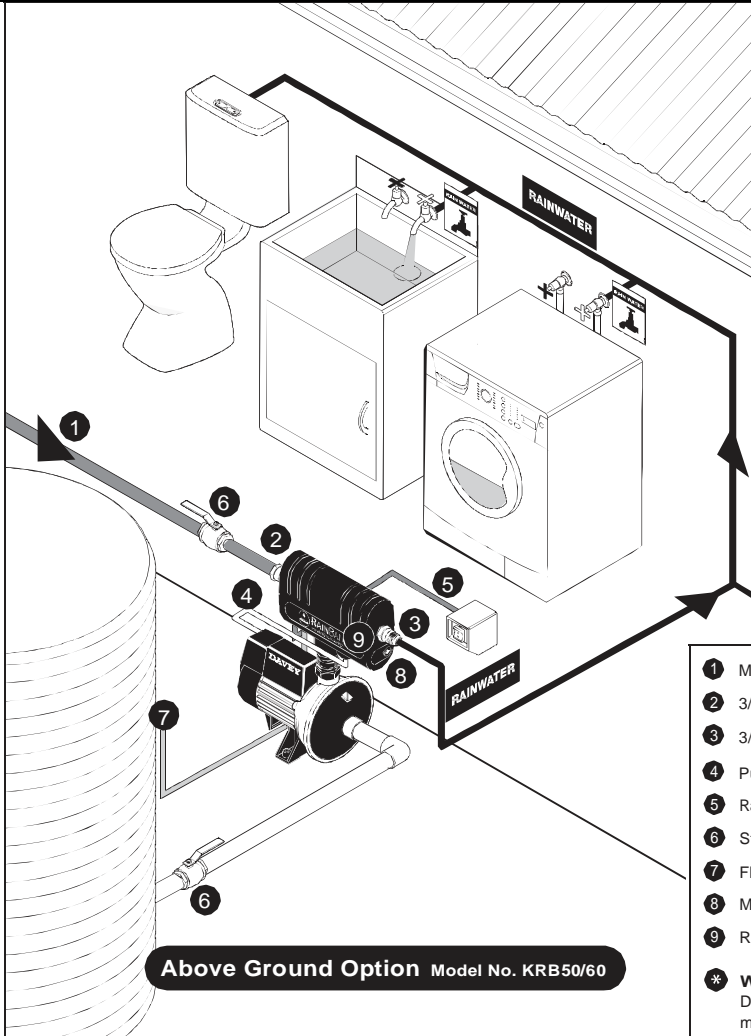

- 1 Mains water supply
- 2 3/4" BSP Female thread
- 3 3/4" BSP Male thread
- 4 Pump Power lead
- 5 RainBank® Power lead
- 6 Stop valve
- 7 Float switch
- 8 Manual start button
- 9 Rainwater supply via pump

* **Warning:**
Do not reconnect with
mains water supply

! **Important:**
All pipework and outlet
fittings from RainBank® must
be labelled to AS/NZS 3500

puMp outside tank
optlon - close up

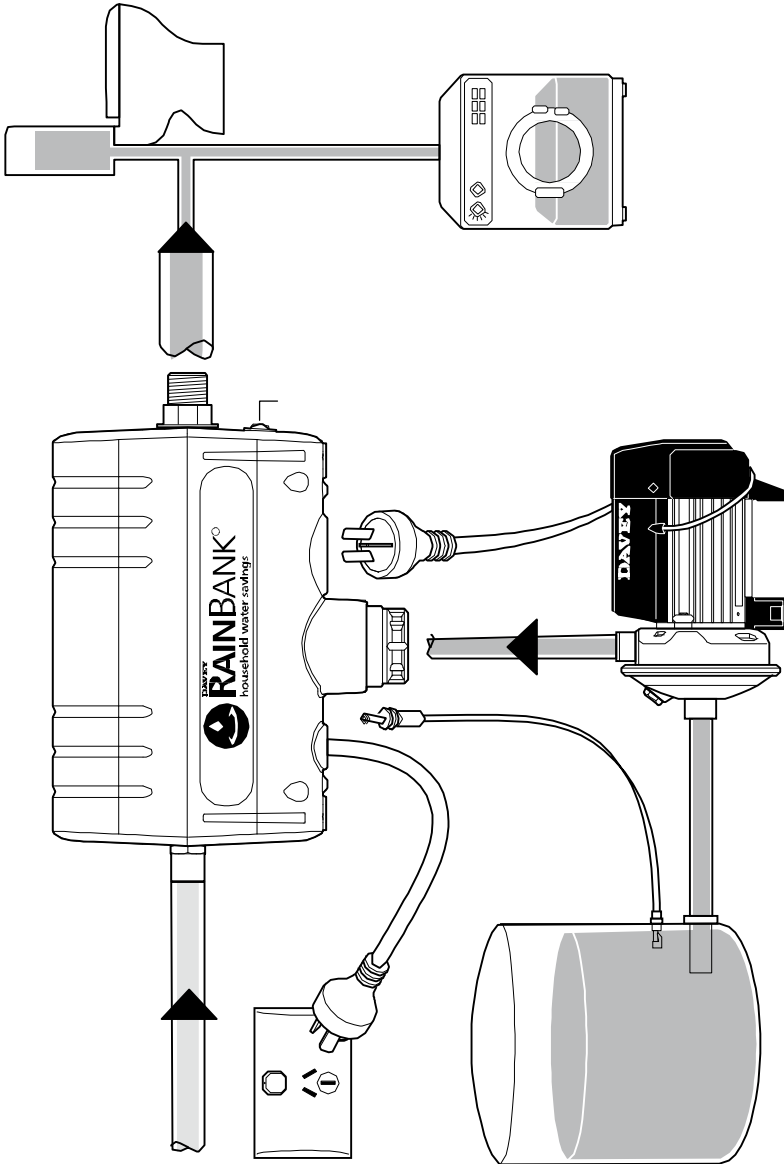

puMp InSIDe tank optIon - oVerall

MoDel no. krb4

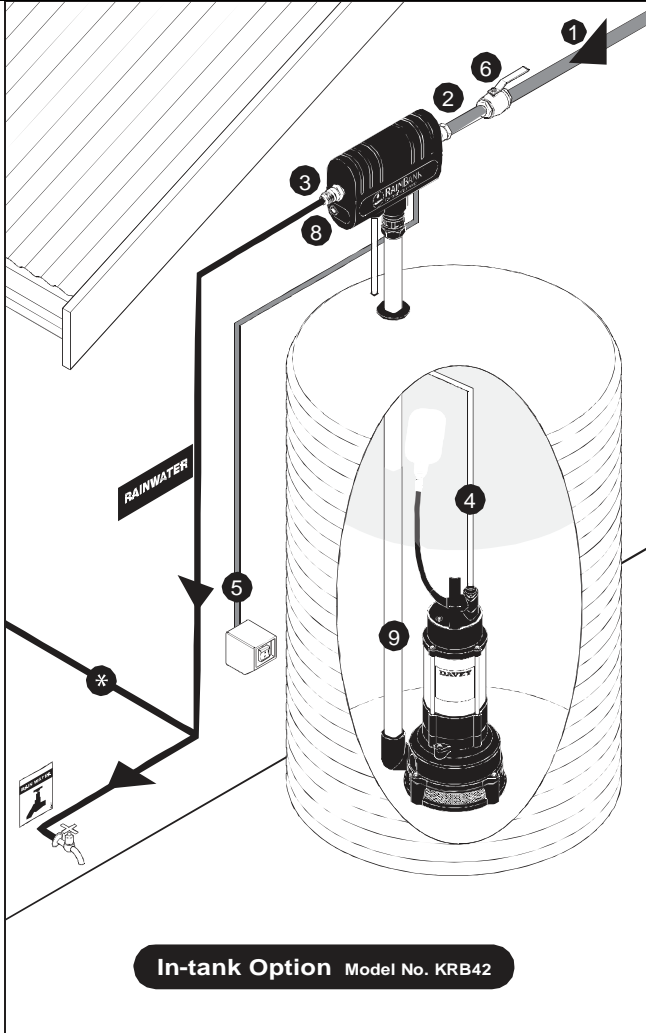

- ① Mains water supply
- ② 3/4" BSP Female thread
- ③ 3/4" BSP Male thread
- ④ Pump Power lead
- ⑤ RainBank® Power lead
- ⑥ Stop valve
- ⑦ Float switch
- ⑧ Manual start button
- ⑨ Rainwater supply via pump

* **Warning:**
Do not reconnect with
mains water supply

⚠ **Important:**
All pipework and outlet
fittings from RainBank® must
be labelled to AS/NZS 3500

puMp InSIDe tank
optlon - close up

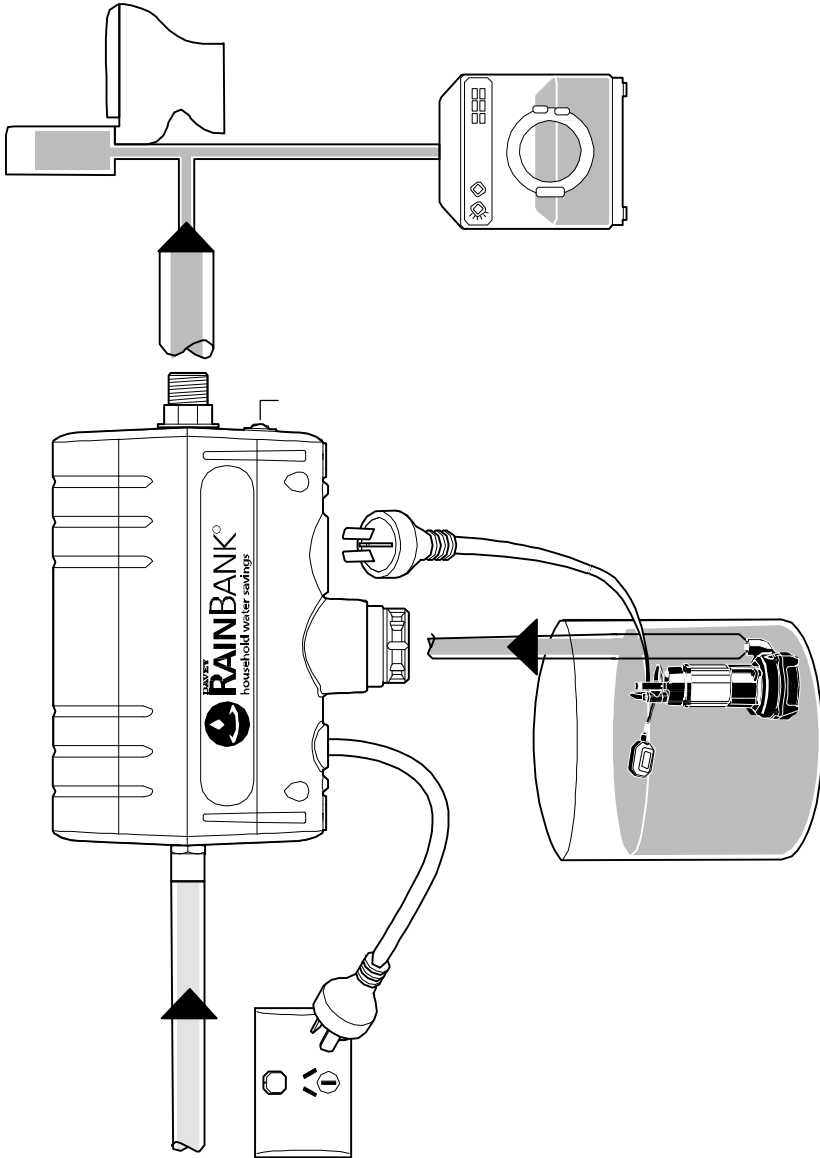

INSTALLATION Type 1

Above ground tank and pump outside tank. suitable kit models: KRB50 or KRB60

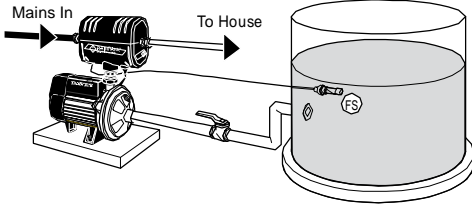

the pump site should be well drained and have a firm base. a concrete slab 600mm x 600mm is ideal.

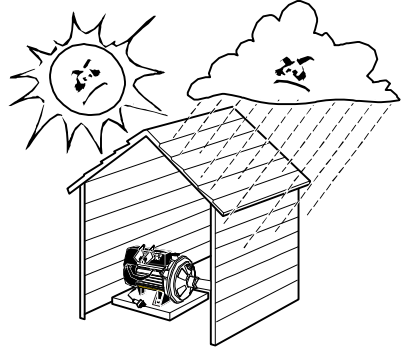

tools you will need

- adjustable spanner 1/2" or 50mm (across flats)
- second adjustable spanner 3/4" or 50mm (across flats)
- thread tape
- 10mm spade bit or hole saw to drill hole in tank for float switch. to avoid leaks and possible failure of the sealing grommet it is important that you use this exact size.
- If you are mounting the rainbank® to a wall as a bare installation you will need the Davey rainbank® wall mounting bracket (part number 07).



IMPORTANT

Do not use long extension leads as they cause substantial voltage drop, poor performance and can lead to motor overload.

check that the float switch lead (5m long) will reach the rainbank®.

sTeP 1 - PuMP POSITION

evaluate and select the best pump site.

this must be below the lowest anticipated level of the float switch and this level should be at least 100mm above the base of the tank to avoid sludge being drawn into the pump.

sTeP 3 - FLoAT sWITCh

Fit float switch to rainwater tank.

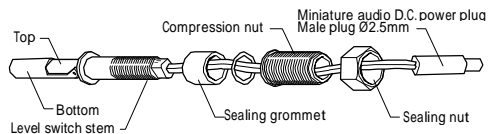

IMPORTANT

- the level switch is suitable for installation in polyethylene and fibreglass tanks. It can be fitted in steel tanks but cutting through the zinc alum or colourbond coating of the tank exposes bare steel and this can rust. Check with the tank manufacturer before drilling.
- the float switch is designed to be installed from the outside of the tank. There is no need to get inside the tank.
- the sealing grommet of the float switch is designed to work in a maximum tank wall thickness of 5mm. It is not suitable for concrete or very thick plastic walled tanks. There is an alternative float switch that can be lowered into the top of these types of tanks (Davey part number 1 449).

Work out the correct position for the hole for the float switch. With a corrugated profile tank wall this is on the upper flat section of the profile as shown below.

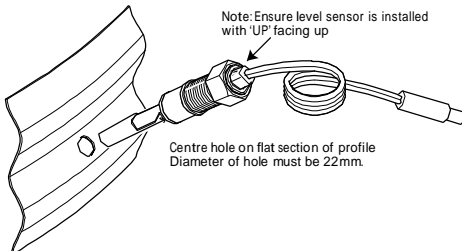

Work out the correct location of the float switch relative to the pump outlet.

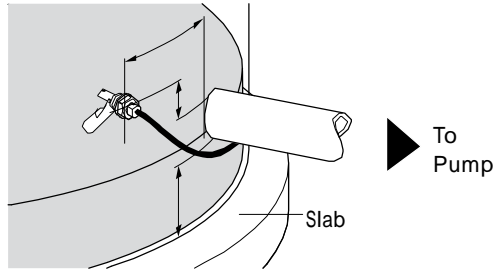

the float switch location should also be:

- at least 40mm above the pump inlet.
- placed away from the rainwater entry into the tank so that the incoming flow does not interfere with the operation of the switch.

before cutting the hole check again that the 5m lead from the float switch will reach the rainbank® and plug comfortably into it.

1. Drill a 22 mm hole in the side of the tank in the correct position. A hole saw is the best tool for this job. Ensure all swarf is removed from the hole. If installing the switch in a corrugated tank you should make sure that it is installed on the flat section between the radii as shown below.

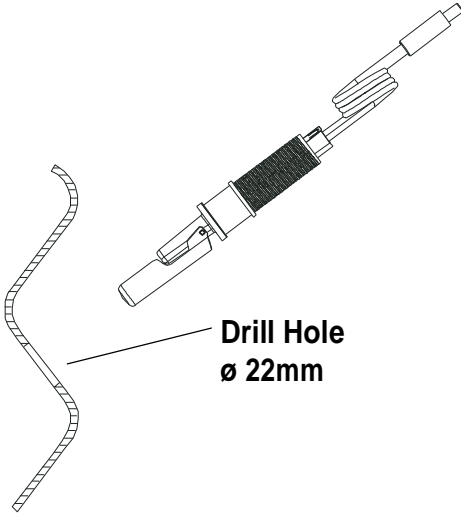

- ensure the compression nut is loosened so that the sealing grommet is not expanded. Remove the sealing nut and insert the switch into the hole as below.

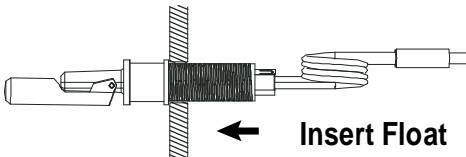

- the switch will not work properly if it is not properly orientated. Make sure the word "up" is seen at the very end of the switch body. Now tighten the compression nut to expand the seal (as shown below).

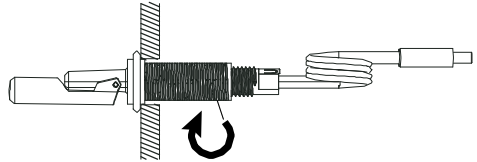

Tighten compression Nut

4. ensure that the switch is still correctly orientated. With the word "up" visible, screw on and tighten the sealing nut to finish the installation of the float switch.

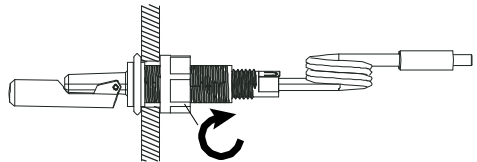

Tighten sealing Nut

STEP 4 - CHECK PIPE WORK

Make sure the final assembled position of your rainbank® will align well with the mains and rainwater pipe.

The pump and rainbank® should be assembled so that the mains water supply to the unit and rainwater outlet to toilets and laundry connect easily to the plumbing on the same level.

sTeP 5 - cONNecT PuMP TO RAINBANK®

connect your pump to the rainbank®

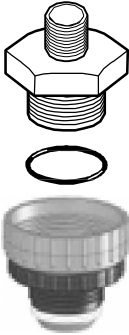

1. apply 10 turns of teflon tape to small thread of adaptor and screw into base of rainbank®.

. screw rotary coupling into outlet of pump (teflon tape not required).

. check oring is in position on adaptor and fit to rotary coupling.

HAND TIgHTeN ONly.

sTeP 6 - cONNecT PIPes

connect the rainbank® to the mains water and delivery pipe plumbing.

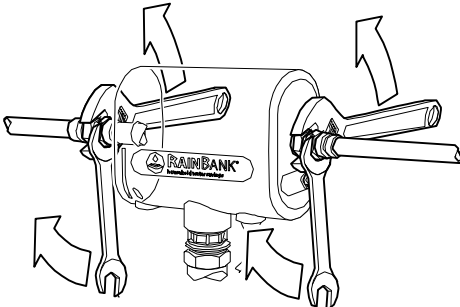

⚠ IMPORTANT

- to allow easy connection it is strongly recommended that you have flexible copper pipes that allow some movement so that they can line up exactly with the mains water and rainwater outlet. these pipes must be $\frac{1}{4}$ inch in diameter.

- It is highly recommended that an isolation valve be fitted to where the mains water enters rainbank® and between the pump and the rainwater tank. this facilitates easy removal of the unit if required without turning off the household water or losing stored rainwater.

- Do not connect any plumbing to rainbank® without bracing against this turning force with a suitable spanner to prevent twisting inside the unit. If you do not do this the unit may be damaged internally and as a result leak.

- Do not use thread sealing compounds, hemp or pipe glue.

- Do not use the rainbank® unit as a lever to force the plumbing into position. this can damage the internal parts of the unit.

- If your access to the bottom of the rainbank® unit is difficult you may have to connect the 12 volt connection from the float switch before the plumbing is connected.



IMPORTANT

this must connect to the rainbank® controller not the power point. If the pump is connected to the power point the pump will run constantly, shortening the life of the pump and potentially running the pump dry.

connect all leads.

sTeP 7

1. connect the pump power lead to the three-pin socket underneath rainbank®.

- connect the three-pin power plug from the rainbank® to your power point.
- connect the 12 volt lead from the float switch to its plug; in the underside of the unit. this is not necessary if you are using a submersible pump as the float switch is already part of the pump.

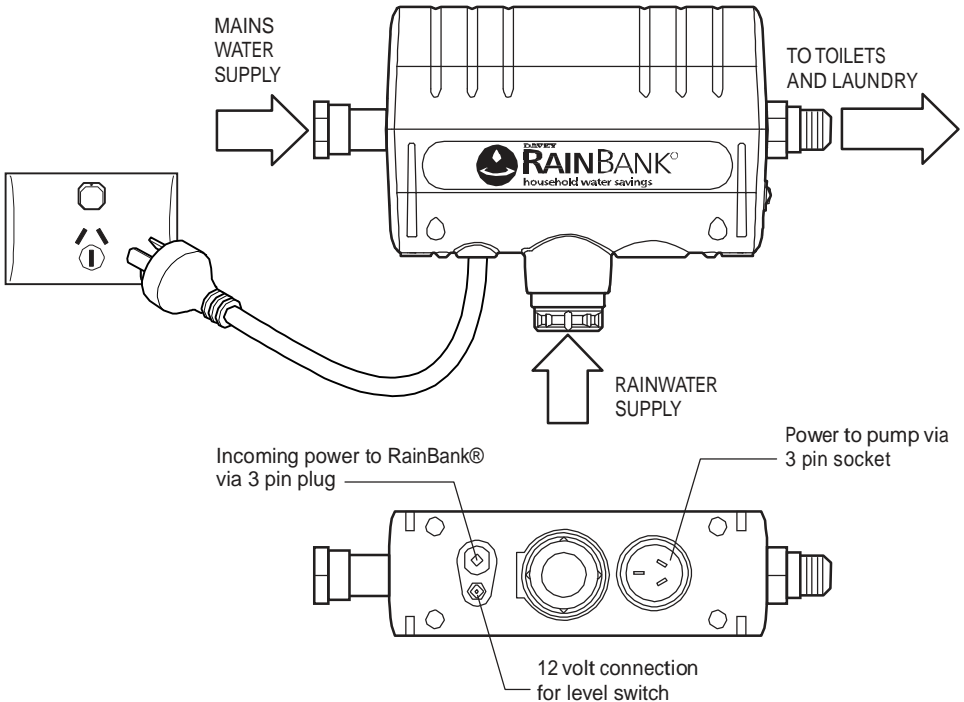

IMPORTANT

be careful not to mistake one of the deep screw holes for the 1 volt connection point.

to protect against electrical surges and lightning strike damaging rainbank® or its pump we strongly recommend the use of a suitable surge protection device and residual current devices.

STeP 8 - TestING

test the operation of rainbank®.

1. With the mains connected and the rainwater tank empty turn on one of the taps in the laundry that feed the washing machine or flush the toilet. Mains water should flow normally. the pump should **not** turn on. When this is completed turn off tap.
- Fill the rainwater tank with sufficient water to activate or cover the float switch.
- check that the pump is correctly primed and there are no air locks that will interfere with its operation as per the Davey instructions. this is essential for the proper operation of the unit. see the instructions on how to do this for all types of Davey pump in the priming section on page 6.

4. turn on a tap or flush a toilet in the rainwater system. the pump should run and deliver rainwater. allow to run for several minutes to clear air from pipes.
5. remove the float switch connection from the rainbank® – this should stop the pump and confirms that the float switch and power connections have been made correctly – refit the float switch connection. press the manual override button to operate the pump if needed.
6. check for leaks around rainbank®, the pump, pipework and fittings.

INStAllATIOn TyPe 2 **Above ground tank with** **submersible pump inside eg:** **KRB42**

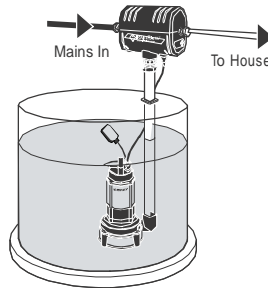

IMPORTANT

- this type of pump comes with its own float switch system to detect water level so it is not necessary to drill the tank to fit a float switch.

- Failure to prime the submersible pump prior to connection of the pump to rainbank® can cause an air lock that may prevent the pump operating properly.

The following sections of the Type 1 installation instructions are applicable to Type 2 installations.

step 2 – Work out the position of your rainbank® with regard to distance to power. the float switch lead is not an issue here.

step 4 – align the rainbank® for easy fitting to the plumbing and fit Davey wall bracket if required.

step 5 – connect rainbank® to your submersible pump as per instructions on page 5.

step 6 – connect the rainbank® to the plumbing as for Installation type 1 on page 19.

step 7 – connect all leads as per Installation type 1 on page 0. there is no float switch lead as this is fitted to the submersible pump.

step 8 – test the unit - page 1.

INSTALLATION Type 3

below ground tank with submersible pump D4 a/b

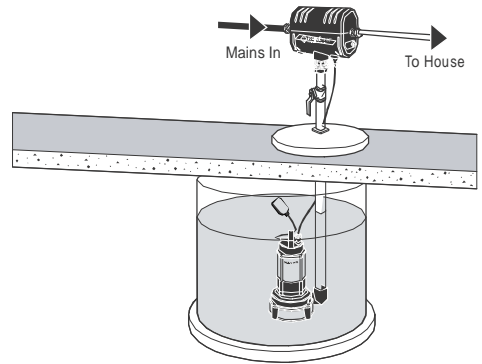

⚠ IMPORTANT

- under australian standard 500 collecting/storing rainwater in a buried tank is considered a medium level hazard. even though rainbank® has a built-in dual check back flow valve, you may be required to fit additional backflow protection valves to satisfy this requirement – check with your local council as to their guidelines on rainwater tank installation and backflow prevention.

there is no need for a separate float switch as this comes attached to the submersible pump and does not plug into the rainbank® unit.

you should carry out the following steps as per the instructions for Installation Type 1

step 2 – Work out the position of your rainbank® with regard to distance to power. the float switch lead is not an issue here.

step 4 – align the rainbank® for easy fitting to the plumbing. Fit Davey wall bracket.

step 5 – connect rainbank® to your submersible pump as per instructions on page 5.

step 6 – connect the rainbank® to the plumbing.

step 7 – connect all leads (no float switch lead to plug in)

step 8 – test the unit - page 1

INSTALLATION Type 4 Below ground tank with pump above tank and suction lift

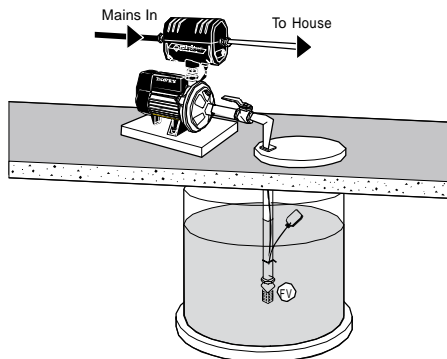

! IMPORTANT

- under australian standard 500 collecting/storing rainwater in a buried tank is considered a medium level hazard. even though rainbank® has a built-in dual check back flow valve you may be required to fit additional backflow protection valves to satisfy this requirement.
- a suction lift (pump above water level) will require a foot valve in the bottom of its uptake pipe in order to retain prime.
- this type of installation uses a different type of float switch designed for use with concrete tanks (part number 1 449).

The following sections of the Type 1 installation instructions are applicable to Type 4 installations.

step 1 – evaluate and select the best pump site as close to the water source and water level as possible.

step 2 – Work out the position of your rainbank® with regard to distance to power. the float switch lead will need to be the concrete tank version p/n 1 449 for lowering into a below ground tank – do not use the standard float switch supplied with rainbank®.

step 3 – plumb up your suction plumbing ensuring that the lowest point in the inlet pipe work has a good quality ‘foot valve’. the foot valve must be positioned at least 100mm below the lowest water level.

step 4 – Install the float switch (part number 1 449). the float end should be set up so it can fall no lower than 100mm above the level of the top of the foot valve so the pump will always be shut off well before it can run dry or draw in air.

this is secured to the pump suction pipe with cable ties. allow no more than 100mm of cable between the float and the lowest cable tie.

the plug end should be plugged into the float switch inlet on the underside of the rainbank® unit in step 8.

step 5 – align the rainbank® for easy fitting to the plumbing.

step 6 – connect rainbank® to the pump.

step 7 – connect rainbank® to the plumbing.

step 8 – connect all leads.

step 9 – test the unit - page 1.

Installation of submersible puMps

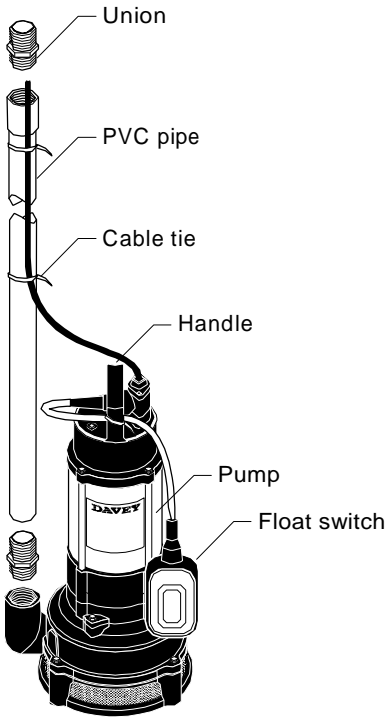

1. use teflon tape on the pipe to pump connection.
- . secure the power cable to the delivery pipe with cable ties.

. place pump into tank.



IMPORTANT

Do not pull on power lead. Fit a rope to handle for lowering and raising pump.

4. Davey recommends the fitting of floating inlets to submersible pumps to minimize any possibility of sludge intake.

priming pumps

Type 1 installations. Above ground tank and pump outside tank.

1. remove the priming plug on the top of the pump and fill the casing and suction line with water then refit plug. If there is an isolation valve fitted on the delivery pipe from the rainwater tank (as recommended) this needs to be opened first.

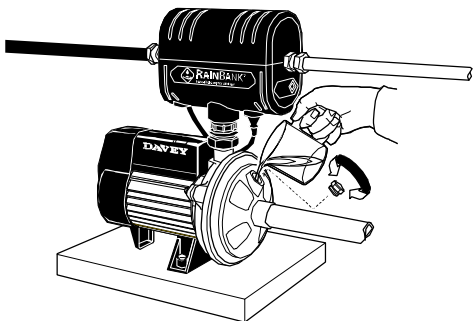

If there is an air lock i.e. the pipe and pump casing is not fully filled with water, the pump may not draw. If this is the case you should repeat the priming procedure. If the pump still does not draw properly this may be a fault in the way the delivery pipe is installed. The pump should be slightly higher than the pipe inlet and this should run up hill to the pump at a slight but consistent slope so that any air is expelled at the pump end as the pump is primed.

IMPORTANT

Leaky joints can also cause a loss of prime.

note: the pump must be below the float switch.

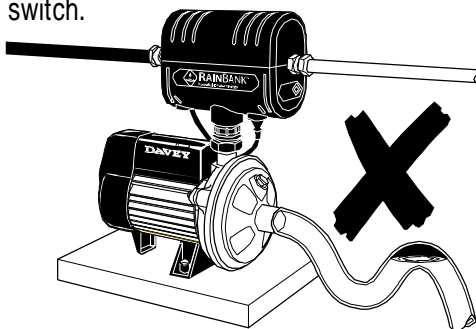

Type 2 and 3 installations. submersible pumps inside tank.

provided the pump is sitting in sufficient water the pump will self prime and push air out of the taps and appliances that are used at the other end. to let this air out without causing damage it is important that:

- all taps connected to the rainwater system are turned on
- toilets connected to the system are flushed so the cistern fills and any air is cleared from the line.

Type 4 installations. external suction pump drawing from below ground tank.

this type of installation requires a foot valve. the top of this should be at least (00mm) below the lowest water level for reliable operation.

priming is as for type 1 installations. If there is a significant amount of water required to do this it can be a good idea to fit the highest area of the pipe with an access plug in a t piece so that the pipe can be filled more quickly with a bucket when repriming.

Maintaining rainbank®

rainbank® does not need maintenance but there are things you can do to ensure its most reliable operation.

- Fit a “first flush” system that ensures the first run of dirty rainwater does not go into the tank.
- clean your gutters regularly.
- remove branches that over hang your roof.
- have a strainer fitted to your rainwater tank inlet and regularly check this for leaves and twigs, etc.
- You should also check for debris in the bottom of your tank a few times a year and clean this out if necessary. a first flush system will greatly reduce the need for this action.
- this automatic thermal overload switch can start the pump without warning. always disconnect the controller and/or pump motor from the electrical supply before maintenance or repairs.
- care should also be taken when servicing or disassembling pump to avoid injury from hot pressurised water. unplug the pump, relieve the pressure by opening a tap on the discharge side of the pump and allow any hot water to cool before attempting to dismantle.
- Do not use petroleum based fluids or solvents (e.g. oils, kerosene, turpentine, thinners, etc on the plastic or seal components).
- Do not use hydrocarbon based or propelled sprays around the electrical components of the controller.



IMPORTANT MAINTeNANcE PReCaUtiONs

- Davey pump motors are fitted with an automatic thermal overload switch that stops the motor if the motor gets too hot to avoid damaging it. this automatically re-starts the motor when the temperature within the pump has dropped to a safe level. constant tripping of this switch indicates a problem e.g. low voltage at pump, etc.
- During servicing use only approved non petrochemical based oring and gasket lubrication. If unsure consult your Davey dealer for advice.

syMPTOM: PuMP WIll NOT sWITCh OFF

- 1. Pump plugged directly into power outlet.** plug lead from pump into base of rainbank® as per installation instructions.
- 2. yellow 'manual override' button pushed in too far.**
pry out the section of the yellow button that has been pushed into the rainbank® housing with a small flat blade screwdriver.
- 3. Water is still being used.**
check all taps, toilets and appliances connected to rainbank® system to ensure they are turned off.
- 4. Water is leaking on discharge side of RainBank® system.**
repair leak.
- 5. Rock or debris caught inside RainBank®.**
call your plumber to fit a Y strainer
- rainbank® will need to be returned to Davey.

syMPTOM: PuMP WII NOT sWITcH ON

- 1. Pump not plugged in.**
plug pump into base of rainbank® and rainbank® into power supply.
- 2. No power supply to pump.**
contact electrician and have power restored.
- 3. Float switch not connected to RainBank®.** plug float lead into base of rainbank®. the connection port is located next to the power lead coming from the rainbank®. to confirm the connection is correct, depress yellow button, pump will start.
- 4. No water in tank.**
check water level in tank.
- 5. Float switch located at water tank is installed incorrectly.**
check to see if the word “up” is facing up on float switch.
- 6. Mains water supply not connected to RainBank.**
rainbank® system must have a pressurised water supply connected to inlet. press yellow “manual override” button to simulate mains water flowing.
- 7. Mains supply to RainBank® turned off.** turn on mains water supply.
- 8. Pump is faulty.**
to confirm if the fault is within the pump, plug the pump directly into power point and check to see if it starts. If the pump starts plug the pump back into the rainbank® and continue fault finding. If the pump does not start contact your supplier for further advice.
- 9. Lead from float switch to pump broken or damaged.**
replace float and lead assembly.
- 10. Float switch defective.**
contact your supplier for further advice.

OTHeR syMPTOMs:

Mains water is still in use when pump is running. possible cause - pump needs to be primed. remove priming plug from front top of pump (right above water inlet) and allow all air to escape from pump. replace the priming plug when water dribbles out of hole (see page 6).

Mains water is still in use when pump is running. possible cause - pumps capacity for high flow has been exceeded and mains water is topping up demand. reduce the amount of water required. this scenario is most likely to occur when using the pump to run pop up sprinklers or other irrigation systems.

Mains water is still in use when pump is running. possible cause - pump impeller blocked. have pump serviced. Fit first flush devices and Y strainer to pipework.

Mains water not passing through RainBank®. possible cause - rainbank® installed backwards. Install rainbank® according to installation & operating instructions.

Mains water not passing through RainBank®. possible cause - debris is blocking inlet to rainbank®. remove rainbank® and clean inlet.

Pump hums. possible cause - pump is jammed or seized. have pump serviced.

Water leaking from drain holes in RainBank®. possible cause - installer has not held fitting when connecting pipes to rainbank® and has damaged internal connections. replace rainbank®.

Water leaking from connection between pump and RainBank®. possible cause - connection kit is not tight. remove rainbank® and re-install connection kit.

Water leaking from connection between pump and RainBank®. possible cause - installer has failed to fit connection kit correctly. remove rainbank® and re-install connection kit.

Float switch pops out of tank. possible cause - hole in tank is too large. Installer to drill correct size hole or fit float switch adaptor part number 1 708sp.

Warnings

- before installing your rainbank® controller, please read all instructions carefully as failures caused by incorrect installation or operation are not covered by the guarantee. Your rainbank® controller is designed to handle clean water. the system should not be used for any other purpose without specific referral to Davey. the use of the system to pump flammable, corrosive and other materials of a hazardous nature is specifically excluded.
- Warning: Water freezing inside the rainbank® will damage the unit. locate your rainbank® and pump so that they are not susceptible to freezing.
- rainbank® must be installed and serviced by a licensed plumber.
- check with your local water authority on water restrictions when your rainwater tank is connected to mains water.
- Do not enter a empty rainwater tank - they may contain hazardous gases.
- secure all openings to the rainwater tank to ensure it will not permit access to children.

DaVeY guarantee

DAVEY WATER PRODUCTS GUARANTEE FOR AUSTRALIA & NEW ZEALAND

Davey rainbank® controller is guaranteed for a period of two years from the date of original purchase to be free of material or manufacturing defects. Should any part fail as a result of such defects within this period, the controller will be repaired free of charge.

TERMS AND CONDITIONS

1. This guarantee applies to all states and territories of Australia and New Zealand only and is subject to the provisions of the Trade Practices Act (Aust.), the Goods and Consumer Protection Legislation of the various Australian states and the Consumers Guarantee Act 199 (nZ) as applicable.
 - The guarantee period commences on the date of original purchase of the equipment. Evidence of this date of original purchase must be provided when claiming repairs under guarantee. It is recommended you retain all receipts in a safe place.
 - This guarantee covers parts and workshop labour only. Goods should be forwarded, with proof of date of original purchase, to an authorised Davey service centre freight paid.
4. This guarantee is subject to due compliance by the original purchaser with all directions and conditions set out in the Installation and Operating Instructions. Failure to comply with these instructions, damage or breakdown caused by fair wear and tear, negligence, misuse, incorrect installation, chemical or additives in the water, inadequate protection against freezing, rain or other adverse weather conditions, corrosive or abrasive water, lightning or high voltage spikes or through unauthorised persons attempting repairs are not covered under guarantee. The product must only be connected to the voltage shown on the nameplate.
5. Without limiting the original purchaser's entitlements under the Trade Practices Act (Aust.), the Goods & Consumer Protection Legislation of the various Australian states, or the Consumers Guarantee Act 199 (nZ), Davey shall not be liable for any loss of profits or any consequential, indirect or special loss, damage or injury of any kind whatsoever arising directly or indirectly from the product or any defect.
6. Where the Trade Practices Act (Aust.), the Goods and Consumer Protection Legislation of the various Australian states and the Consumers Guarantee Act 199 (nZ) does not apply, Davey shall not be liable for any loss of profits or any consequential, indirect or special loss, damage or injury of any kind whatsoever suffered by the purchaser arising directly or indirectly from the product or any defect and the purchaser shall indemnify Davey against any claim by any other person whatsoever in respect of any such loss, damage or injury.
7. Nothing in this guarantee is intended to have the effect of contracting out of the provisions of the Trade Practices Act (Aust.), the Goods and Consumer Protection Legislation of the various Australian states and Consumers Guarantee Act 199 (nZ) except to the extent permitted by the various acts and this guarantee is to be modified to the extent necessary to give effect to that intention.
8. Davey may be collecting personal information from you in order to provide you with a service. Davey Water Products Pty Ltd promises only to use this information in accordance with the provisions of the Privacy Act 1988 (Cth) and the privacy policy of Davey Water Products Pty Ltd which is available at davey.com.au.

© Davey and rainbank are registered trademarks of Davey Water Products Pty Ltd.
rainbank patented.

© Davey Water Products Pty Ltd 007.

Davey Water Products Pty Ltd

Member of the GUD Group

ABN 18 066 327 517

Head Office and Manufacturing

6 Lakeview Drive,
Scoresby, Australia 3179

Ph: +61 3 9730 9222

Fax: +61 3 9753 4100

Website: davey.com.au

Customer Service Centre

Ph: 1300 367 866

Fax: 1300 369 119

E-mail: sales@davey.com.au

Interstate Offices

Sydney • Brisbane • Adelaide

Perth • Townsville

International

6 Lakeview Drive,
Scoresby, Australia 3179

Ph: +61 3 9730 9121

Fax: +61 3 9753 4248

E-mail: export@davey.com.au

Germany

Kantstrasse 47,
04275 Leipzig

Ph: +49 341 301 0412

Fax: +49 341 301 0413

E-mail: akrenz@daveyeurope.com

New Zealand

2 Rothwell Avenue,
North Harbour, Auckland 1330

Ph: +64 9 914 3680

Fax: +64 9 914 3685

Website: daveynz.co.nz

E-mail: sales@daveynz.co.nz

USA - Davey Pumps Inc.

1005 N. Commons Drive
Aurora, Illinois 60504

Ph: +1 630 898 6976

Fax: +1 630 851 7744

Website: daveyusa.com

E-mail: sales@daveyusa.com